

Interfacing Ag1460 with IDT 821068

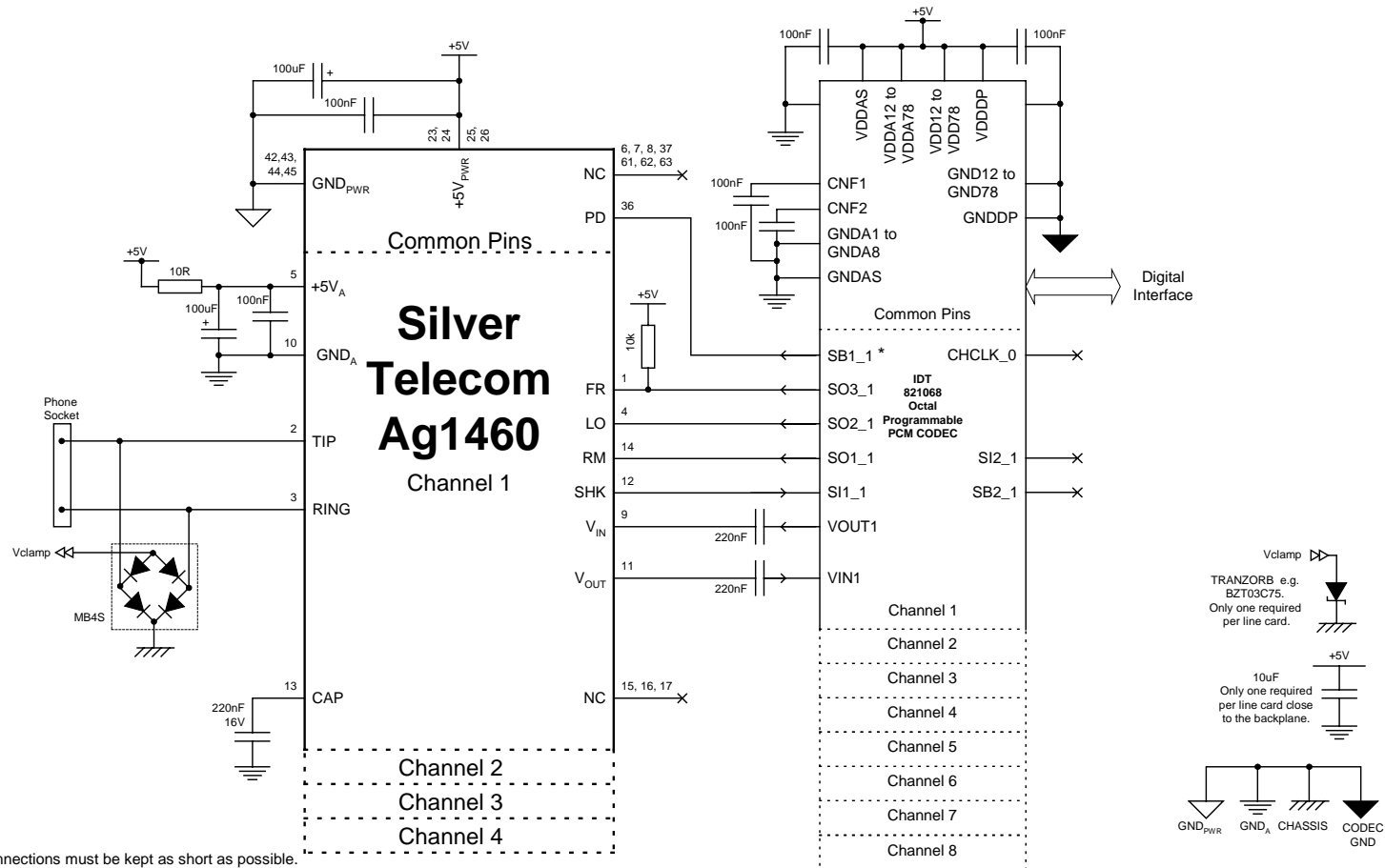

Notes:

1. All signal connections must be kept as short as possible.
2. Pin numbers as for Ag1460 SIL channel 1. Two Ag1460 should be used with each IDT821068.
3. It is recommended that the hardware ring trip function is used with SI1_(x) and SO1_(x) with a 10ms debounce time.
4. The Ag1460 is hardware configured for 600Ohm output and network balance impedance.
5. Depending on the application more protection may be required at TIP and RING.
- *. Only SB1_1 is used and is configured as an output. SB1_2 to SB1_8 are not required.

AN1460-7v2-0