

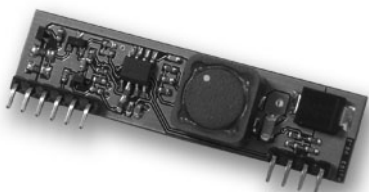

Ag102

Intelligent Sealed Lead Acid Battery Charger Module



1 Features

- Multi-Stage Charging
- Battery Reversal Protection
- Reduced Power Consumption
- Wide DC or AC Input Voltage Range
- High Efficiency DC-DC Converter
- Intelligent 'Top-up' Float Charge
- Programmable Charge Current
- Battery Condition Indicator Output
- Temperature Compensation
- Overload & Short-circuit Protection
- Simple Integration

2 Description

The Ag102 is a micro-processor based intelligent, cost effective, sealed lead acid (SLA) battery charging module. It uses digital technology to optimise the charging of standard, 12V sealed lead acid batteries between 1.2Ah and 7Ah capacity. Using various intelligent charging techniques the Ag102 technology will maximise the manufacturers specified battery lifetime.

The Ag102 has a very wide input range of 9V to 36V DC. This gives extensive flexibility and means the system and charger requires just one, lower cost, power supply. When used in conjunction with Silvertel's Power over Ethernet (PoE) module, the Ag102 can charge SLA batteries from power obtained over an Ethernet cable.

Table of Contents

1	Features	1
2	Description.....	1
3	Ag102 Product Selector†	3
4	Pin Description	4
5	Functional Description	5
5.1	Operation.....	5
5.2	Input	6
5.3	Capacity Select.....	7
5.4	Thermal Compensation	8
5.5	Status Output.....	9
5.5.1	Mode 0 – Normal Operation	10
5.5.2	Mode 1 – Battery Capacity Warning	10
5.5.3	Mode 2 – Defective or Disconnected battery	11
5.5.4	Mode 3 – Over Temperature	11
5.5.5	Mode 4 – Over Current.....	11
6	Typical Application.....	11
7	Operating Temperature Range.....	12
8	Protection	13
8.1	Battery Reversal Protection	13
8.2	Over Current & Short Circuit Protection.....	13
8.3	Over Temperature Protection	13
9	Electrical Characteristics	14
9.1	Absolute Maximum Ratings*.....	14
9.2	Recommended Operating Conditions.....	14
9.3	DC Electrical Characteristics*.....	14
10	Package	15

2.1 Table of Figures

Figure 1:	Block Diagram with External Components.....	3
Figure 2:	Ag102 SIL Package Format.....	4
Figure 3:	Basic Ag102 Charge Profile.....	5
Figure 4:	Input Connections – DC or AC Input.....	6
Figure 5:	Capacity Select.....	7
Figure 6:	Output Adjustment.....	8
Figure 7:	STAT Output Configurations.....	9
Figure 8:	STAT Output Timing	10
Figure 9:	Typical Application.....	12

3 Ag102 Product Selector†

Part Number	Input Voltage	Output Voltage	Battery Capacity	Marking	Package
Ag102S	9V to 36V	12V	1.2Ah to 7Ah	Ag102	SIL

† The Ag102 fully meets the requirements of the RoHS directive 2002/95/EC on the restriction of hazardous substances in electronic equipment.

Table 1: Ordering Information

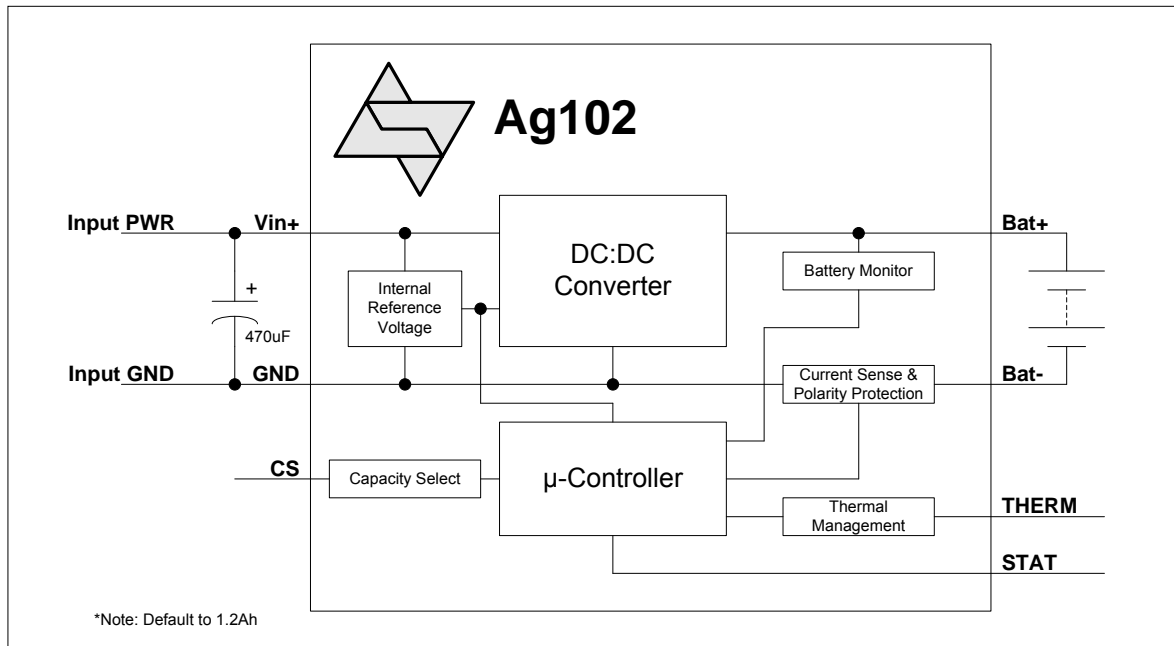

Figure 1: Block Diagram with External Components

4 Pin Description

Pin	Name	Description
1	VIN+	Positive Supply (Input). This pin connects to a positive dc supply (9V to 36V).
2	VIN+	Positive Supply (Input). This pin connects to a positive dc supply (9V to 36V).
3	CS	Capacity Select (Input). This pin connects to an external resistor to set the capacity of the battery to be charged (1.2Ah to 7Ah).
4	STAT	Charge Status (Output). This output pin is used to indicate the battery status.
5	GND	Ground Return (Input). This pin connects to the ground return of the power supply.
6	GND	Ground Return (Input). This pin connects to the ground return of the power supply.
7	THERM	Thermistor (Input). The pin can be connected to an external Thermistor to add temperature compensation (if required).
8	BAT-	Battery Negative (Output). The output pin connects to the battery negative terminal. It must NOT be connected directly to the GND pin.
9	BAT-	Battery Negative (Output). The output pin connects to the battery negative terminal. It must NOT be connected directly to the GND pin.
10	BAT+	Battery Positive (Output). The output pin connects to the battery positive terminal.

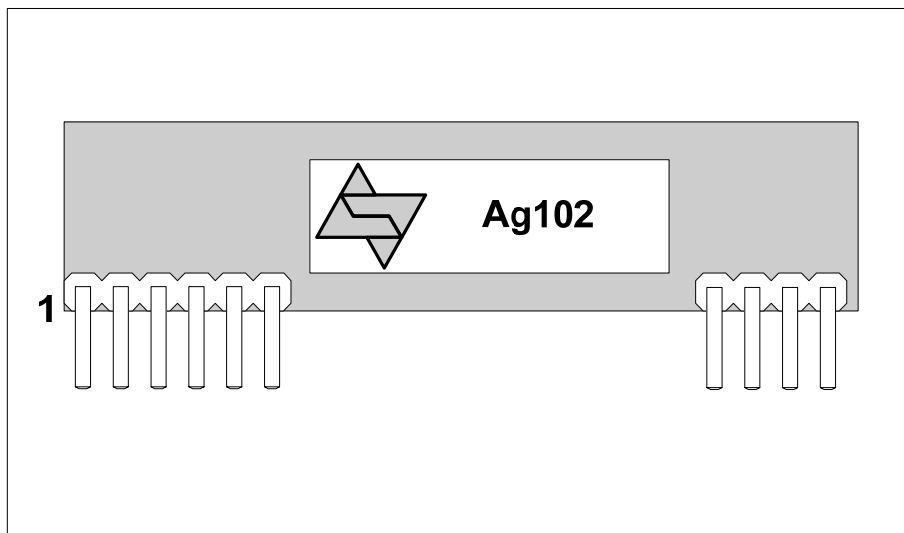

Figure 2: Ag102 SIL Package Format

5 Functional Description

5.1 Operation

When power is applied, the Ag102 reads the CS input and sets the charge profile for the selected battery capacity (see Section 5.3).

In many safety critical systems it is essential that the battery is charged quickly with no stress or damage. The Ag102 achieves this using an optimum multi-stage charge cycle, shown in Figure 3.

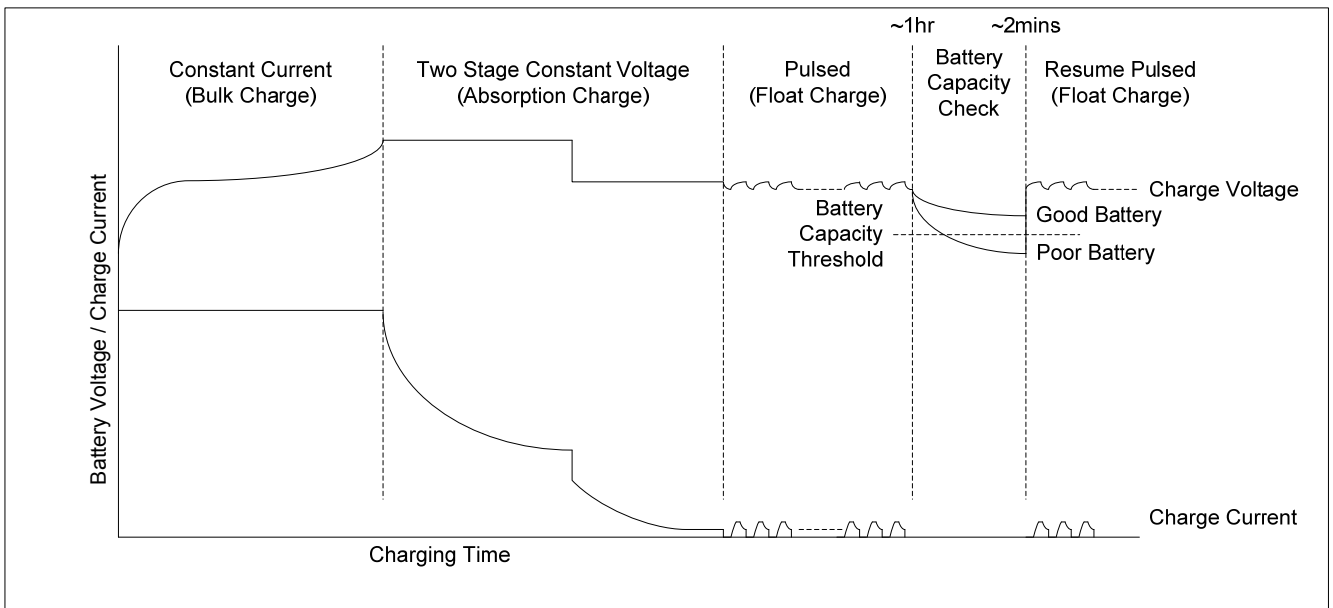

Figure 3: Basic Ag102 Charge Profile

Battery manufacturers recommend using multi-stage charging to reduce the stress on the battery while giving the shortest possible charge time.

The Ag102 implements the ideal charging cycle by applying a higher bulk charge voltage for 70% - 80% of the charge cycle and a lower absorption charge voltage for the remaining 20% - 30%. This is done to prevent the battery from gassing as it approaches full charge.

Once the battery has reached the optimum level, the Ag102 will continue to top up the battery using an intermittent float charge.

The charge profile can be further optimised by using thermal compensation (see Section 5.4).

5.2 Input

The Ag102 has a very wide input range of 9Vdc to 36Vdc, making this module extremely flexible. For stable operation it is recommended to fit a 470 μ F capacitor across the input pins, as close to these pins as possible.

The Ag102 can be powered from an AC power supply with the addition of an external bridge rectifier. It is important that the rectified voltage across the input pins is within the 9Vdc to 36Vdc limits, Figure 4 shows examples of both methods.

For optimum efficiency the input voltage should be set between 12V and 18V.

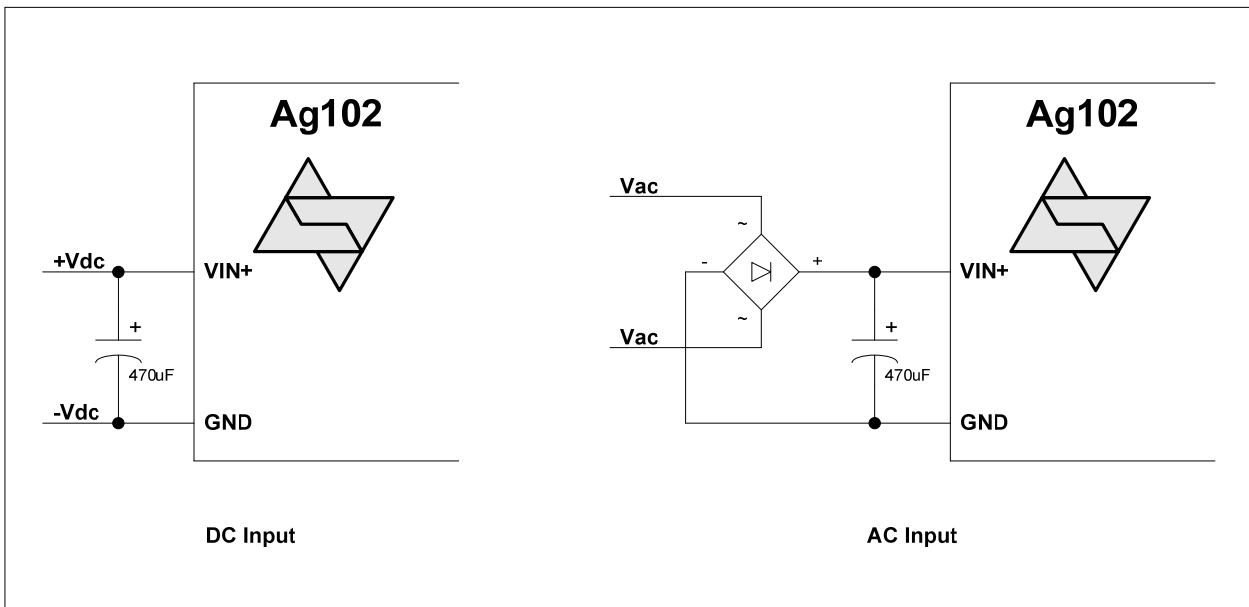

Figure 4: Input Connections – DC or AC Input

5.3 Capacity Select

The Ag102 is capable of charging a range of SLA batteries from 1.2Ah up to 7Ah. Setting the CS input couldn't be easier, all that is required is a resistor between the CS pin and the GND pin, see Figure 5.

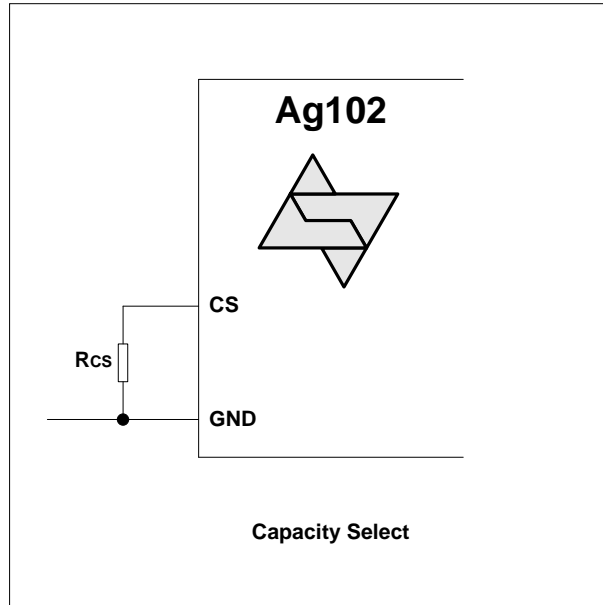

Figure 5: Capacity Select

The CS pin has an internal pull up resistor to a voltage reference which sets the voltage on this pin. This voltage is measured at start-up and the optimum charge profile for the battery is programmed. The value of R_{CS} is shown in Table 2.

Battery Capacity (Ah)	R_{CS} Resistance (Ohms)*	Min Input Voltage (V)	Voltage at the CS Pin (V)	Bulk Charge Current Limit (A) $\pm 10\%$
1.2	1K $\pm 1\%$	9	0.5	0.3
2	2K7 $\pm 1\%$	9	1	0.5
2.1	4K3 $\pm 1\%$	9	1.5	0.525
2.3	6K8 $\pm 1\%$	9	2	0.575
2.8	10K $\pm 1\%$	9	2.5	0.7
3.2	15K $\pm 1\%$	12	3	0.8
4	24K $\pm 1\%$	12	3.5	1
7	43K $\pm 1\%$	12	4	1

Table 2: Value of R_{CS}

* To prevent damaging the battery it is important that the correct value of R_{CS} is set. If R_{CS} is not fitted, then the Ag102 will default to 1.2Ah capacity.

5.4 Thermal Compensation

The optimum terminal voltage for the charging process is also dependent on battery temperature. This is because the electrochemical activity is affected by temperature changes. Therefore, as the temperature rises, the charging voltage should be reduced to prevent overcharge. Likewise as the temperature falls, the charge voltage should be increased to avoid undercharge. In order to attain optimum service life (maximising the life of the battery), the use of temperature compensation is highly recommended.

The Ag102 make this easy to implement, with only the addition of a low cost Thermistor, connected so the battery temperature can be monitored. The Ag102 measures the THERM pin and will automatically adjust the charge profile to compensate for any changes in battery temperature.

TH1* shown in Figure 6 is a 47K NTC (Negative Temperature Coefficient) resistor with $B(K) = 4000$. These are inexpensive and readily available in surface mount or bead format.

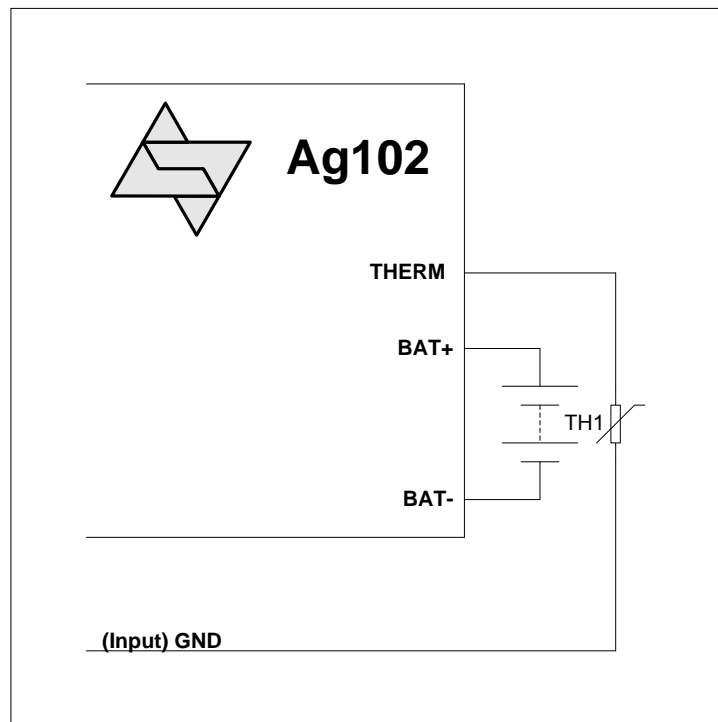

Figure 6: Output Adjustment

* For correct operation the Thermistor must be in physical contact with the battery.

When using thermal compensation, if the battery temperature exceeds 50°C, the Ag102 will shut-down the DC-DC converter and the output status indicator (STAT) will report an over temperature error.

The Ag102 will default to a 25°C charge profile if TH1 is not fitted.

5.5 Status Output

The Ag102 has a status indication output pin 'STAT'; that can be connected to a μ -controller input (as shown in Figure 7) for full status monitoring.

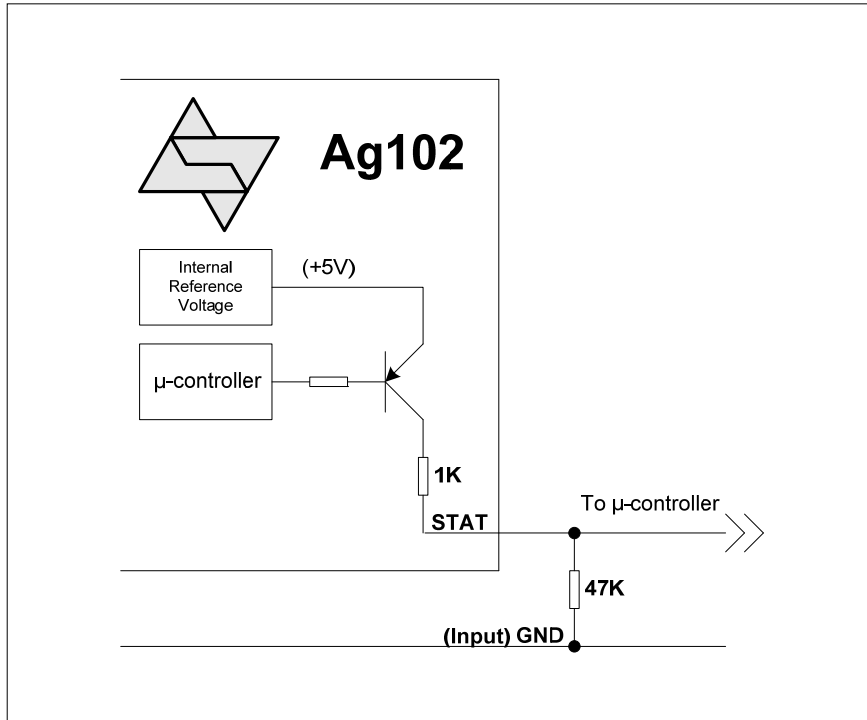

Figure 7: STAT Output Configurations

Note: Figure 7 shows a 47K pull down resistor, this is required to ensure that the open collector output switches correctly (but this is not a critical value), the STAT output can source ~5mA.

Table 3, shows the different mode conditions of the Ag102: -

Mode	Status Mode	STAT Output
0	Normal Operation	Steady State 'Logic 1'
1	Battery Capacity Warning	1 Inverse Pulse
2	Defective or Disconnected Battery Error	1 Pulse
3	Over Temperature Error	2 Pulses
4	Over Current Error	3 Pulses

Table 3: STAT Output Conditions

Figure 8 shows the timing of the STAT output in more detail: -

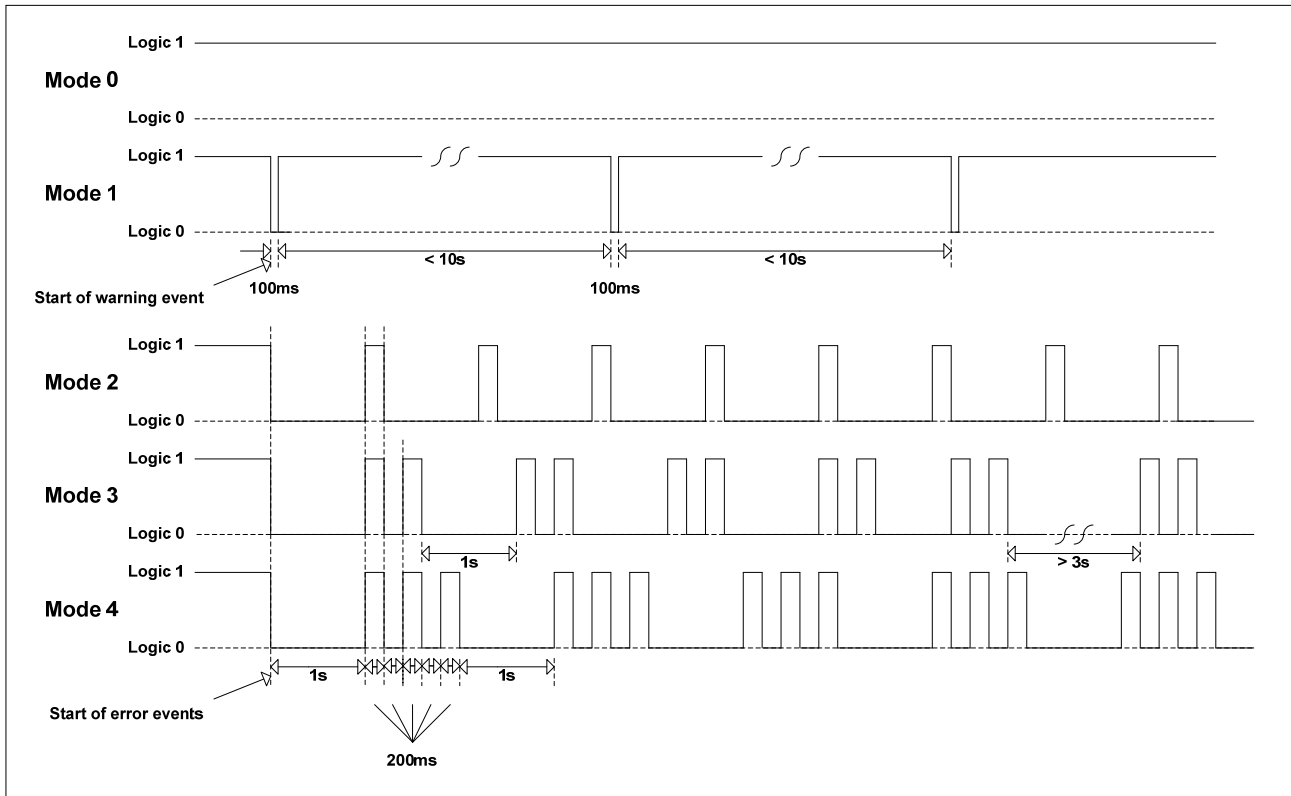

Figure 8: STAT Output Timing

5.5.1 Mode 0 – Normal Operation

During a normal charge cycle the 'STAT' output will be a steady state 'Logic 1' (Mode 0).

After the Ag102 has entered the float cycle it will periodically check the battery capacity - approximately once an hour. It does this by stopping the top-up pulses for a short duration and checking the battery terminal voltage response.

If the battery terminal voltage does not drop below the capacity threshold, the Ag102 will resume operation in Mode 0 and the STAT output will remain at a steady state 'Logic 1',

5.5.2 Mode 1 – Battery Capacity Warning

If the terminal voltage drops below the threshold level (during the battery capacity check), then the Ag102 will go into Mode 1.

In Mode 1 the STAT output will change to indicate a battery capacity low warning by generating an inverse pulse ('Logic 0') for ~100ms (then returns to 'Logic 1'). The interval between these (inverse) pulses can vary, but will usually be < 10 seconds.

It is important to remember that even if the Ag102 detects a low battery capacity it will continue to charge the battery. Mode 1 is a warning that the battery capacity is getting low and that the battery may need to be changed.

If the Ag102 detects an error condition (Modes 2 to 4), then the STAT output will go to 'Logic 0' for 1 second then will send 'Logic 1' pulse(s) with a ~200ms mark (and a ~200ms space between pulses), which will be repeated with ~1 second gap (Mode 3 does have an exception to this which is described in Section 5.5.4).

5.5.3 Mode 2 – Defective or Disconnected battery

If the battery is disconnected or is completely defective, the Ag102 will go into Mode 2 and cycle here until a healthy battery is connected. When a healthy battery is reconnected the Ag102 will return to Mode 0 (normal operation) unless the Ag102 detects a problem.

5.5.4 Mode 3 – Over Temperature

If a battery over temperature condition occurs, the Ag102 will shutdown its DC-DC converter to protect the battery and will go into Mode 3. The STAT pin will output five sets of two pulses with the standard 1s delay in between each set of pulses. But after the fifth set of pulses, the Ag102 will restart to check the temperature during an extended 'Logic 0' period (> 3seconds). If the battery is still over temperature the Ag102 will shut down and continue to cycle on Mode 3. When the Ag102 detects that the battery temperature has dropped below 50°C (the maximum operating temperature), the part will return to Mode 0 (normal operation).

5.5.5 Mode 4 – Over Current

If an output over current condition is detected, the Ag102 will again shutdown its DC-DC converter and will go into Mode 4. This is considered to be a major fault condition and the Ag102 will need to be power cycled to resume normal operation to protect the battery and itself.

6 Typical Application

Figure 9 shows a very simple method of connecting the Ag102.

When the input power is applied RL1 activates and the input is connected directly to the output, the Ag102 will power up and charge the battery. C1 should be positioned as close to the input pins as possible and TH1 should be in physical contact with the battery.

If the power fails then RL1 will deactivate and the battery will be connected to the output. This configuration will momentarily break the output power. If this is not suitable then alternative configurations are available (please contact Silver Telecom Ltd for more details).

It is also very important that the GND and Bat- pins are not connected together. Other application drawings using a single pole change-over relay or solid state switching (MOSFET) are also available.

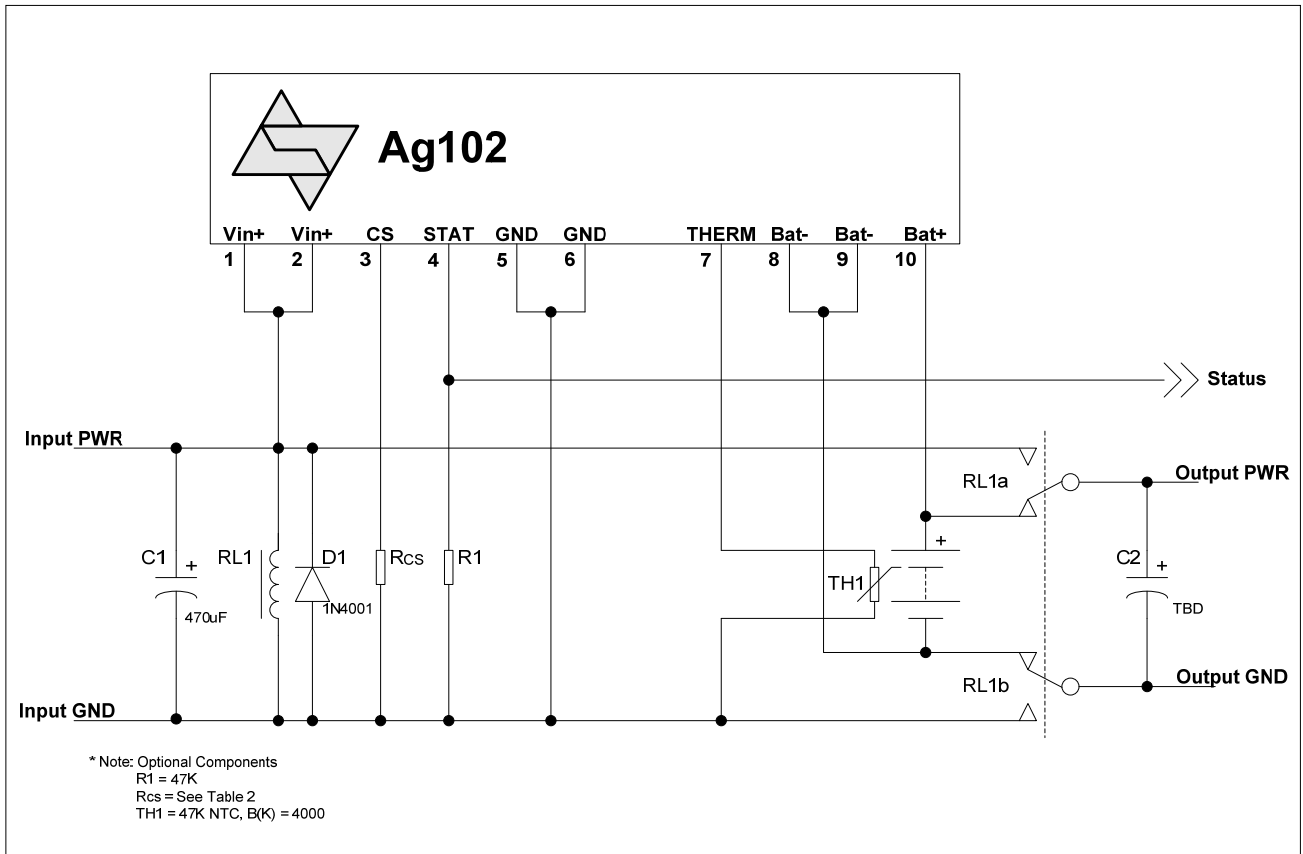

Figure 9: Typical Application

7 Operating Temperature Range

For most applications the Ag102 will be position close to the battery and the maximum operating temperature will be limited by the battery to 50°C. However if the battery is being charged remotely, then under certain conditions the Ag102 can be run at higher temperatures (please contact Silver Telecom Ltd for more details).

8 Protection

The Ag102 offers three primary protection circuits: -

8.1 Battery Reversal Protection

If the battery connections are accidentally reversed, the Ag102 will not power the DC-DC converter and the output status indicator (STAT) will report a battery disconnected condition. The Ag102 is internally protected from damage by reverse battery connection.

8.2 Over Current & Short Circuit Protection

The Ag102 output has over current (and short circuit) protection. This is triggered when the output current exceeds 200mA above the bulk charge current shown in Table 2. If an over current fault is detected, the Ag102 will shut-down the DC-DC converter and the STAT output will report an over current error.

8.3 Over Temperature Protection

This is only activated when using thermal compensation. If the battery temperature exceeds 50°C, the Ag102 will shut-down the DC-DC converter and the STAT output will report an over temperature error.

9 Electrical Characteristics

9.1 Absolute Maximum Ratings*

	Parameter	Symbol	Min	Max	Units
1	DC Supply Voltage	V_{CC}	-0.3	40	V
2	Storage Temperature	T_S	-40	+100	°C

*Exceeding the above ratings may cause permanent damage to the product. Functional operation under these conditions is not implied. Maximum ratings assume free airflow.

9.2 Recommended Operating Conditions

	Parameter	Symbol	Min	Typ	Max	Units
1	Input Supply Voltage	V_{IN}	9	12	36	V
2	Operating Temperature	T_{OP}	-20	25	50†	Ta / °C

†See Section Operating Temperature Range

9.3 DC Electrical Characteristics*

	DC Characteristic	Sym	Min	Typ*	Max	Units	Test Comments
1	Bulk Charge Constant Current	I_{OUT}		See Table 2		A	
2	Absorption Charge Voltage 1	$V_{OUT1\ddagger}$	14.28	14.4	14.52	V	
3	Absorption Charge Voltage 2 & Float Charge Voltage	$V_{OUT2\ddagger}$	13.53	13.65	13.77	V	
4	Battery Capacity Threshold Voltage	V_{TH}		12.9		V	After 2 mins
5	STAT Output Low Voltage Output High Voltage	V_{OL} V_{OH}	4.5		0.5	V V	With external 47K pull-down resistor
6	Output Ripple and Noise (at the battery terminal)	V_{RN}		100		mVp-p	7Ah battery
7	DC-DC Converter Efficiency	EFF_{DC}		88		%	
8	Charger Efficiency	EFF_{BAT}		86		%	
9	Short-Circuit Duration	T_{SC}			∞	sec	

*Typical figures are at 25°C with a nominal input voltage = 12V and are for design aid only. Not Guaranteed

‡Measured between the GND and the BAT+ pins

