

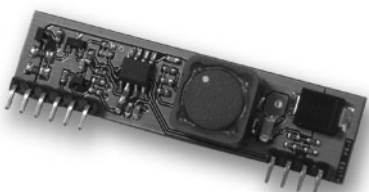

Ag112

Lithium-ion Battery Charger Module



1 Features

- Multi-Stage Charging
- Battery Reversal Protection
- Reduced Power Consumption
- Wide DC or AC Input Voltage Range
- High Efficiency DC-DC Converter
- Programmable Charge Current
- Battery Condition Indicator Output
- Battery Thermal Protection
- Overload & Short-circuit Protection
- Simple Integration

2 Description

The Ag112 is a micro-processor based, intelligent, cost effective, Lithium-ion (Li-ion) and Lithium Polymer (Li-Po) battery charging module. It uses digital technology to optimise the charging of protected Li-ion batteries and implements various intelligent charging techniques to maximise the manufacturers specified battery lifetime.

The Ag112 has a very wide input range of 9V to 36V DC. This gives extensive flexibility and means the system and charger requires just one, lower cost, power supply. When used in conjunction with Silvertel's Power over Ethernet (PoE) module, the Ag112 can charge Li-ion batteries from power obtained over an Ethernet cable.

Table of Contents

1	Features	1
2	Description.....	1
2.1	Table of Figures.....	2
3	Ag112 Product Selector [†]	3
4	Pin Description	4
5	Functional Description	5
5.1	Operation.....	5
5.2	Input	6
5.3	Capacity Select.....	7
5.4	Thermal Protection	8
5.5	Status Output.....	9
5.5.1	Mode 0 – Battery Disconnected	10
5.5.2	Mode 1 – Charging Battery.....	11
5.5.3	Mode 2 – Battery Full	11
5.5.4	Mode 3 – Temperature Error	11
5.5.5	Mode 4 – Over Current.....	11
5.5.6	Mode 5 – Timeout Error	11
6	Typical Application.....	12
7	Operating Temperature Range	13
8	Protection	13
8.1	Battery Reversal Protection	13
8.2	Over Current & Short Circuit Protection.....	13
8.3	Temperature Protection	13
8.4	Protected Cells	13
9	Electrical Characteristics	14
9.1	Absolute Maximum Ratings*.....	14
9.2	Recommended Operating Conditions.....	14
9.3	DC Electrical Characteristics*	14
10	Package	15

2.1 Table of Figures

Figure 1:	Block Diagram with External Components.....	3
Figure 2:	Ag112 SIL Package Format.....	4
Figure 3:	Basic Ag112 Charge Profile.....	5
Figure 4:	Input Connections – DC or AC Input.....	6
Figure 5:	Capacity Select.....	7
Figure 6:	Output Adjustment	9
Figure 7:	STAT Output Configurations.....	9
Figure 8:	STAT Output Timing	10
Figure 9:	Typical Application.....	12

3 Ag112 Product Selector†

Part Number	Input Voltage	Output Voltage	Upper Charge Current	Marking	Package
Ag112-1S	9V to 36V	4.1V or 4.2V	1500mA	1	SIL
Ag112-2S	9V to 36V 12V to 36V	8.2V or 8.4V	1200mA 1500mA	2	SIL
Ag112-3S	12V to 36V 14V to 36V	12.3V or 12.6V	900mA 1200mA	3	SIL

† The Ag112 fully meets the requirements of the RoHS directive 2002/95/EC on the restriction of hazardous substances in electronic equipment.

Table 1: Ordering Information

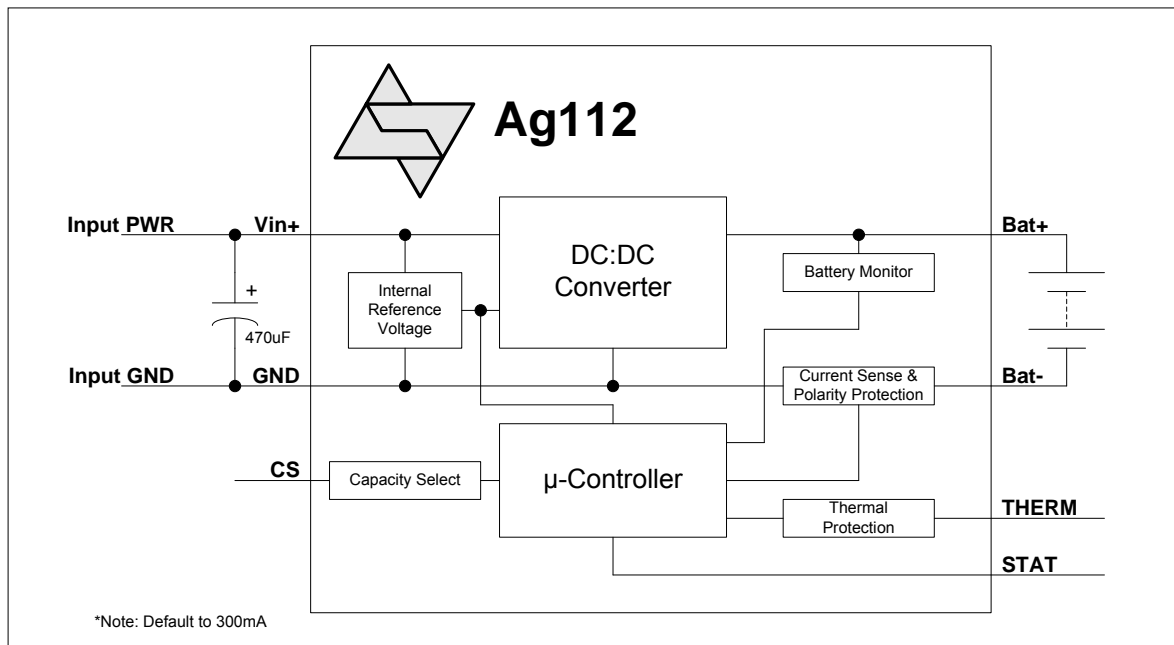

Figure 1: Block Diagram with External Components

4 Pin Description

Pin	Name	Description
1	VIN+	Positive Supply (Input). This pin connects to a positive DC supply (9V to 36V).
2	VIN+	Positive Supply (Input). This pin connects to a positive DC supply (9V to 36V).
3	CS	Capacity Select (Input). This pin connects to an external resistor to set the capacity of the battery to be charged.
4	STAT	Charge Status (Output). This output pin is used to indicate the battery status.
5	GND	Ground Return (Input). This pin connects to the ground return of the power supply.
6	GND	Ground Return (Input). This pin connects to the ground return of the power supply.
7	THERM	Thermistor (Input). The pin must be connected to an external Thermistor to add thermal protection (if required).
8	BAT-	Battery Negative (Output). The output pin connects to the battery negative terminal. It must NOT be connected directly to the GND pin.
9	BAT-	Battery Negative (Output). The output pin connects to the battery negative terminal. It must NOT be connected directly to the GND pin.
10	BAT+	Battery Positive (Output). The output pin connects to the battery positive terminal.

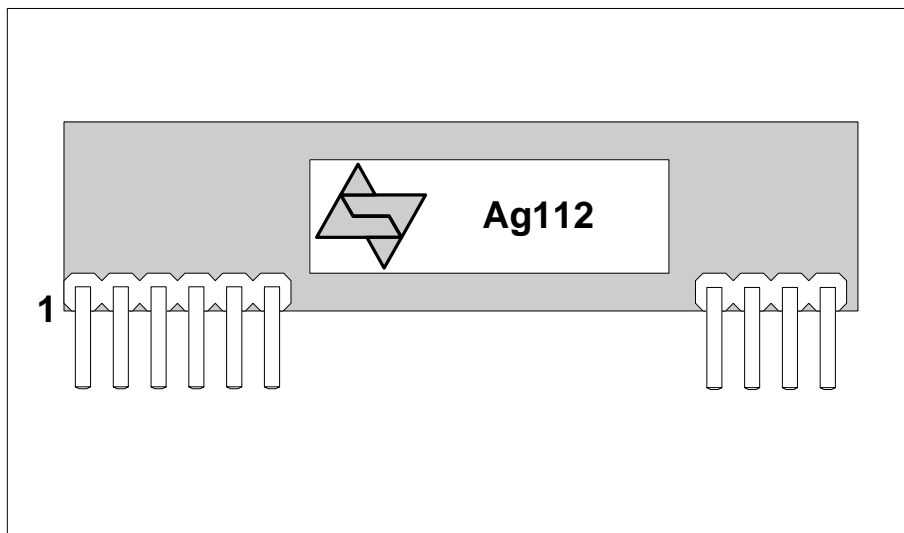

Figure 2: Ag112 SIL Package Format

5 Functional Description

5.1 Operation

Ag112 provides intelligent charging for one, two or three protected Lithium-ion or lithium polymer cells (from 4V to 12V), automatically adjusting charge conditions as required by the battery. This is accomplished as described below: -

When power is applied, the Ag112 reads the CS input and sets the charge profile for the selected battery capacity (see Section 5.3).

Ag112 provides multi-stage charging. Figure 3 shows the charge profile for the Ag112.

The first stage is Pre-Charge; this is only done if the battery voltage is less than 3.0V (per cell). The Pre-Charge applies a constant current equal to the Upper Charge Current \div 10. The Pre-Charge finishes when the terminal voltage reaches 3.3V.

The second stage is the Constant Current charge; this will apply the Upper Charge Current until the terminal voltage reaches its programmed level (4.1V or 4.2V per cell).

The final stage is the Constant Voltage charge; this applies the programmed voltage level (4.1V or 4.2V per cell) until the current drops below the Cut-off Current.

Upon completion of the final stage the STAT output indicator will show that the battery is fully charged. The Ag112 will continue to monitor the battery voltage and will go back into the charge cycle when the terminal voltage drops below 90% of the charge voltage level.

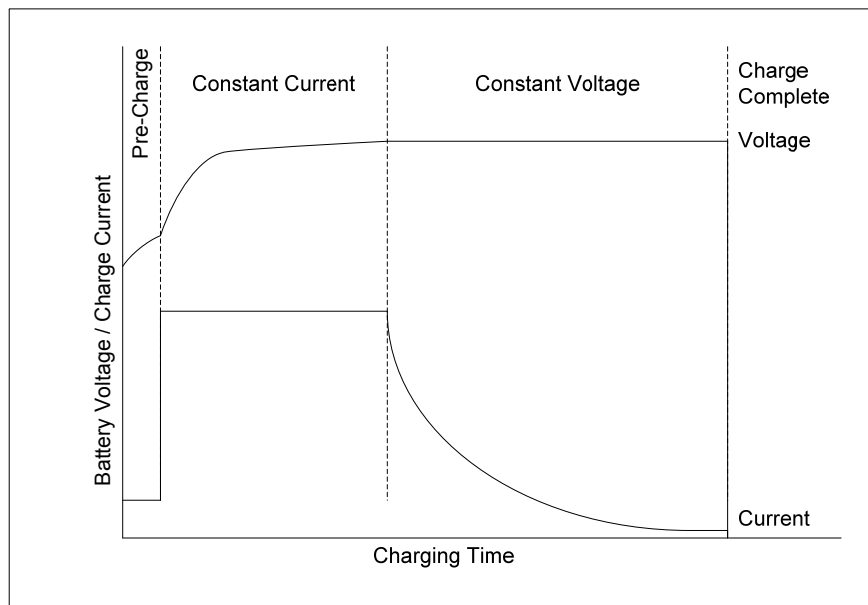

Figure 3: Basic Ag112 Charge Profile

5.2 Input

The Ag112 has a very wide input range of 9Vdc to 36Vdc (see Table 1), making this module extremely flexible. For stable operation it is recommended to fit a 470 μ F capacitor across the input pins, as close to these pins as possible.

The Ag112 can be powered from an AC power supply with the addition of an external bridge rectifier. It is important that the rectified voltage across the input pins is within the 9Vdc to 36Vdc limits, Figure 4 shows examples of both methods.

For optimum efficiency the input voltage should be set between 12V and 18V.

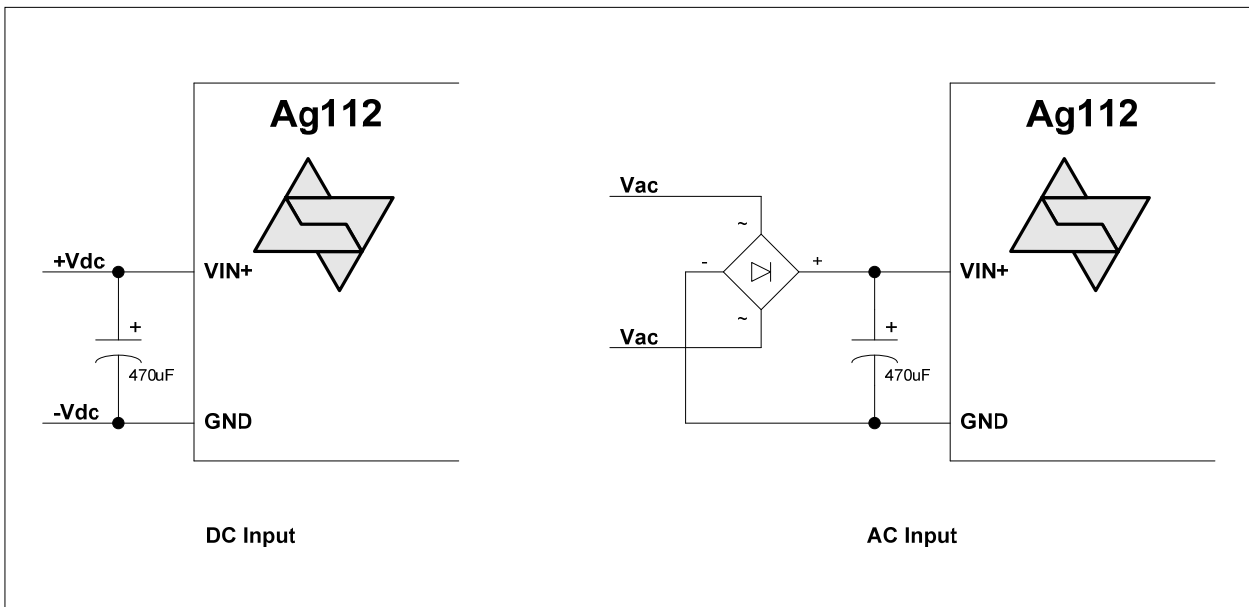

Figure 4: Input Connections – DC or AC Input

5.3 Capacity Select

The Ag112 is capable of charging a range of Lithium-ion batteries. Setting the CS input couldn't be easier, all that is required is a resistor between the CS pin and the GND pin, see Figure 5.

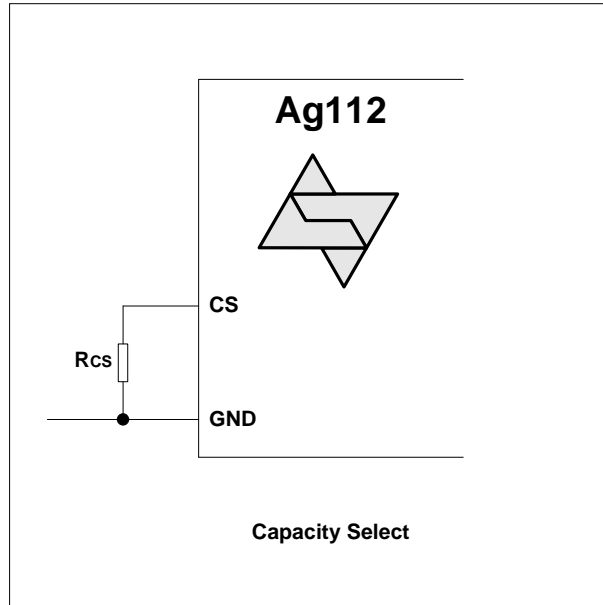

Figure 5: Capacity Select

There are two primary factors that must be considered when selecting the charge profile. The first is upper charge current, this must be $0.8 \times$ battery capacity (or less). The second parameter is the cut-off current, this must be greater than the battery capacity $\div 50$. The value of R_{CS} is shown in Table 2.

Charge Profile No.	R_{CS} Resistance (Ohms)*	Output Voltage Ag112-1S	Output Voltage Ag112-2S	Output Voltage Ag112-3S	Upper Charge Current (mA)	Cutoff Current (mA)
1	2K $\pm 1\%$	4.2	8.4	12.6	300	15
2	3K $\pm 1\%$	4.2	8.4	12.6	600	30
3	3K9 $\pm 1\%$	4.2	8.4	12.6	900	45
4	5K1 $\pm 1\%$	4.2	8.4	12.6	1200	60
5	6K8 $\pm 1\%$	4.2	8.4	N/A**	1500	75
6	9K1 $\pm 1\%$	4.1	8.2	12.3	300	15
7	12K $\pm 1\%$	4.1	8.2	12.3	600	30
8	15K $\pm 1\%$	4.1	8.2	12.3	900	45
9	20K $\pm 1\%$	4.1	8.2	12.3	1200	60
10	27K $\pm 1\%$	4.1	8.2	N/A**	1500	75

Table 2: Value of R_{CS}

* To prevent damaging the battery it is important that the correct value of R_{CS} is set. If R_{CS} is not fitted, then the Ag112 will default to Charge Profile No. 1.

** The Ag112-3S does not support 1500mA upper charge current, charge profile 5 and 10 will automatically revert down a level to the 1200mA profile.

As can be seen from Table 2 there is also an option for selecting the Voltage per cell at either 4.2V or 4.1V. This allows you to either charge the cell to 100% capacity (4.2V) or to ~85% capacity (4.1V). Charging to ~85% capacity is proven to extend the number of charge cycles, but remember, this also means less energy will be available during discharge.

As an example, if you want to charge a single VARTA LIC 18650 WC Li-ion battery to 100% capacity (4.2v) you would need to consider the following:

Charge profiles 1 to 5 could be selected but the upper charge current must be less than the capacity * 0.8. The capacity of this cell is 2200mAh, so $2200\text{mAh} * 0.8 = 1760\text{mA}$, again charge profiles 1 to 5 are all below this.

To prevent damage it is important that you do not set the upper charge current to greater than the battery capacity.

To preserve the life of the battery, the cut-off current must be greater than the battery capacity $\div 50$, $2200\text{mAh} \div 50 = 44\text{mA}$. Profiles 4 & 5 are both greater than this cut-off current; so both would be suitable for charging this battery. Profile 4 will take longer to charge, but has the advantage of drawing less power from the supply and the Ag112 will run cooler.

5.4 Thermal Protection

The Ag112 provides an option for additional thermal protection. This prevents the battery from being charged if its temperature drops below 0°C or goes above 50°C. The Ag112 makes this easy to implement, with the addition of a low cost thermistor.

TH1* shown in Figure 6 is a 10K NTC (Negative Temperature Coefficient) resistor with B(K) ~ 4000. These are inexpensive and readily available in surface mount or bead format.

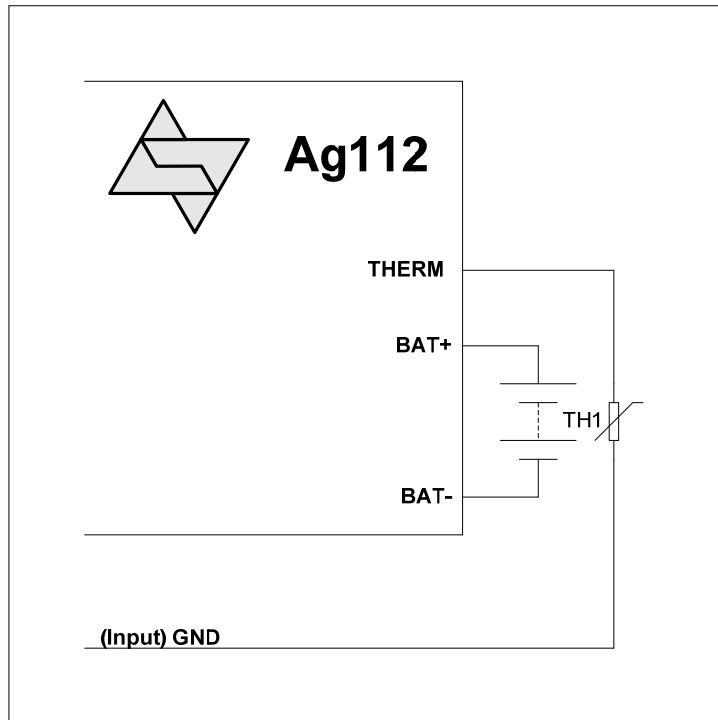

Figure 6: Output Adjustment

* For correct operation the Thermistor must be in physical contact with the battery.

5.5 Status Output

The Ag112 has a status indication output pin 'STAT'; that can be connected to a μ -controller input (as shown in Figure 7) for full status monitoring.

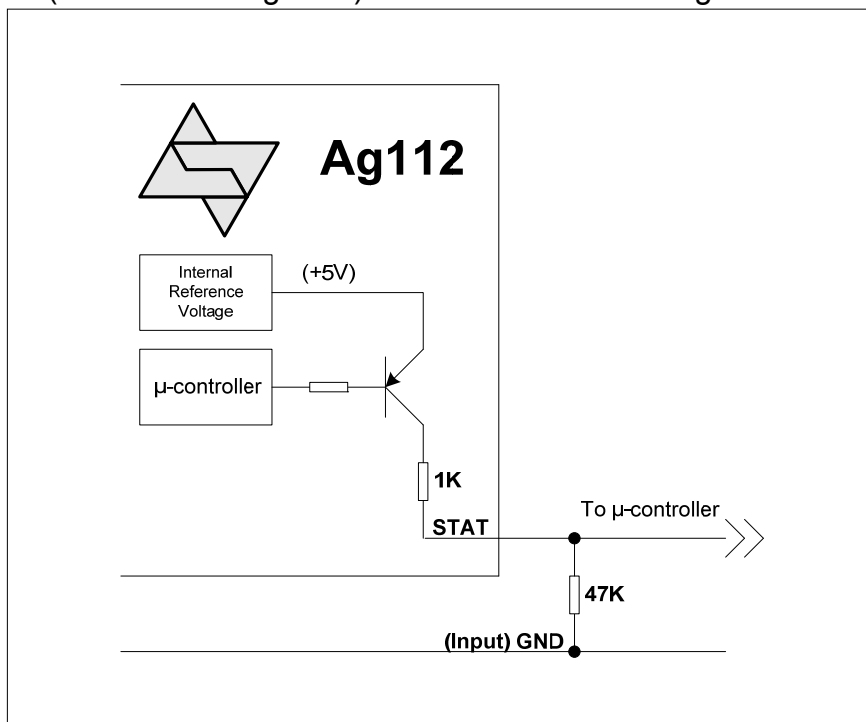

Figure 7: STAT Output Configurations

Note: Figure 7 shows a 47K pull down resistor, this is required to ensure that the open collector output switches correctly (but this is not a critical value), the STAT output can source ~ 5 mA.

Table 3, shows the different mode conditions of the Ag112: -

Mode	Status Mode	STAT Output
0	No Battery Connected	Steady State 'Logic 0'
1	Charging	Steady State 'Logic 1'
2	Battery Full (Charge Complete)	1 Pulse
3	Temperature Error	2 Pulses
4	Over Current Error	3 Pulses
5	Timeout Error	4 Pulses

Table 3: STAT Output Conditions

Figure 8 shows the timing of the STAT output in more detail: -

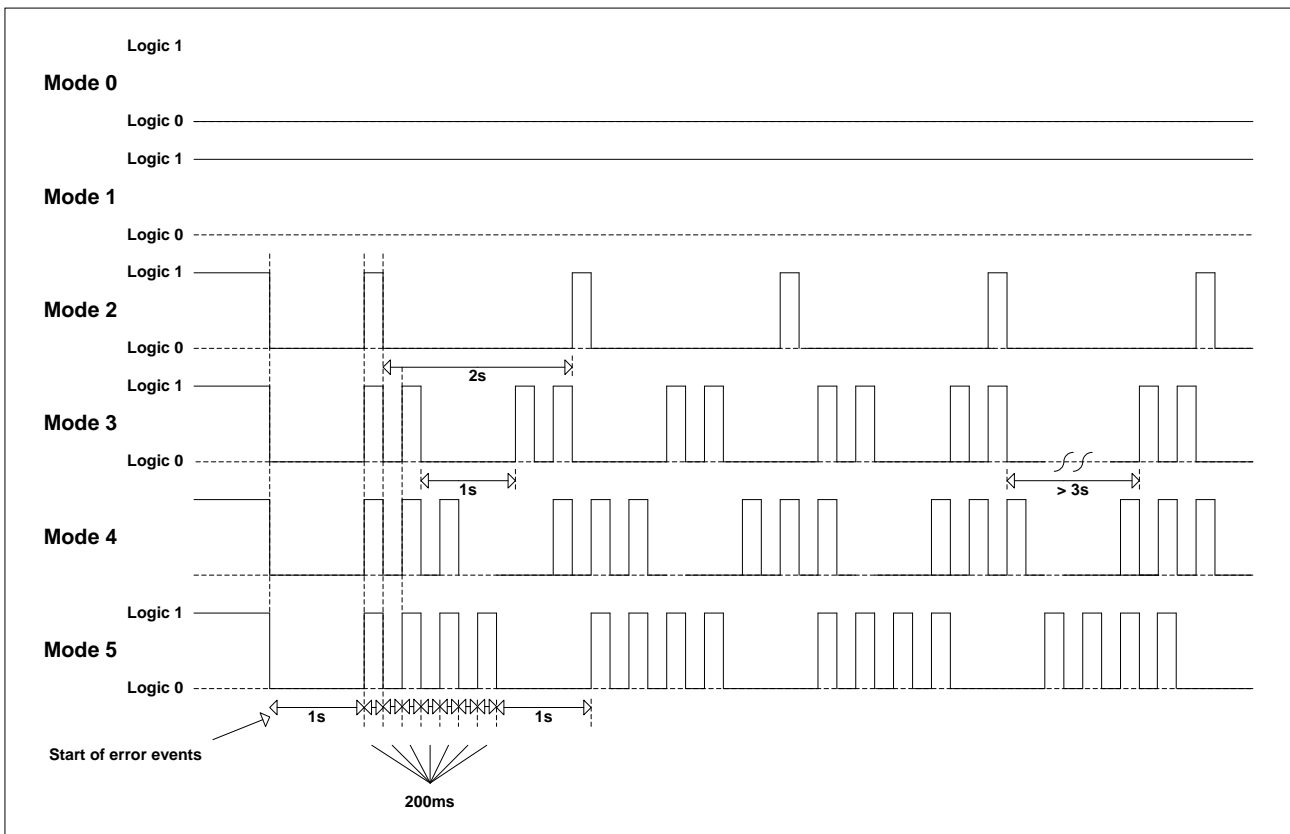

Figure 8: STAT Output Timing

5.5.1 Mode 0 – Battery Disconnected

If the battery is disconnected (or the protection circuit has been activated) the 'STAT' output will be a steady state 'Logic 0' (Mode 0).

5.5.2 Mode 1 – Charging Battery

During a normal charge cycle the 'STAT' output will be a steady state 'Logic 1' (Mode 0).

5.5.3 Mode 2 – Battery Full

When charge current drops below the Cutoff level, the Ag112 will switch its output off. To report that the charge is complete and the battery is full, the STAT output will go to 'Logic 0' for 1 second then will send 'Logic 1' pulse(s) with a ~200ms mark (and a ~200ms space between pulses), which will be repeated with ~2 second gap.

5.5.4 Mode 3 – Temperature Error

If a battery temperature error condition occurs, the Ag112 will shutdown its DC-DC converter to protect the battery and will go into Mode 3. The STAT pin will output five sets of two pulses with a 1s delay in between each set of pulses. But after the fifth set of pulses, the Ag112 will restart to check the temperature during an extended 'Logic 0' period (> 3seconds). If temperature is still out of range the Ag112 will shut down and continue to cycle on Mode 3. When the Ag112 detects that the temperature returns within its operating temperature, the part will return to Mode 1 (Charging Battery).

5.5.5 Mode 4 – Over Current

If an output over current condition is detected, the Ag112 will again shutdown its DC-DC converter and will go into Mode 4. The STAT output will delay 1 second, then send three pulses followed by a 1 second delay (which is repeated). This is considered to be a major fault condition and the Ag112 will need to be power cycled to resume normal operation to protect the battery and itself.

5.5.6 Mode 5 – Timeout Error

If the Ag112 does not exit the Pre-Charge stage within 30 minutes then it considers the battery to be faulty. This will generate a timeout error and the STAT output will delay 1 second, then send four pulses followed by a 1 second delay (which is repeated). This is considered to be a major fault condition and the Ag112 will need to be power cycled to resume normal operation.

The Ag112 does have a second timeout mode that occurs if the complete charge cycle exceeds 6 hours. If this happens the Ag112 will terminate the charge and monitor the terminal voltage to see what action is required. This timeout will not generate a Timeout Error; it is there to protect the battery.

7 Operating Temperature Range

The Ag112 must be positioned close to the battery, therefore the Ag112 operating temperature will be limited by the battery to 0°C to 50°C.

8 Protection

The Ag112 offers three primary protection circuits: -

8.1 Battery Reversal Protection

If the battery connections are accidentally reversed, the Ag112 will not power the DC-DC converter and the output status indicator (STAT) will report a battery not connected condition. The Ag112 is internally protected from damage by reverse battery connection.

8.2 Over Current & Short Circuit Protection

The Ag112 output has over current (and short circuit) protection. This is triggered when the output current exceeds 200mA above the Upper Charge Current shown in Table 2. If an over current fault is detected, the Ag112 will shut-down the DC-DC converter and the STAT output will report an over current error.

8.3 Temperature Protection

This is only activated when using thermal compensation. If the battery temperature exceeds the operating temperature range 0°C to 50°C, the Ag112 will shut-down the DC-DC converter and the STAT output will report a temperature error.

8.4 Protected Cells

The Ag112 is designed for charging protected cells only. These cells have built in control circuits to limit the current to a safe level for that specific cell. Use of the Ag112 with unprotected (bare) cells is not supported by SilverTel.

9 Electrical Characteristics

9.1 Absolute Maximum Ratings*

	Parameter	Symbol	Min	Max	Units
1	DC Supply Voltage	V_{CC}	-0.3	40	V
2	Storage Temperature	T_S	-40	+100	°C

*Exceeding the above ratings may cause permanent damage to the product. Functional operation under these conditions is not implied. Maximum ratings assume free airflow.

9.2 Recommended Operating Conditions

	Parameter	Symbol	Min	Typ	Max	Units
1	Input Supply Voltage	V_{IN}	9	12	36	V
2	Operating Temperature	T_{OP}	0	25	50†	Ta / °C

†See Section 7 Operating Temperature Range

9.3 DC Electrical Characteristics*

	DC Characteristic	Sym	Min	Typ*	Max	Units	Test Comments
1	Upper Charge Current	I_{OUT}		See Table 2		A	
2	Cutoff Current	I_{CUT}		See Table 2		A	
2	Charge Voltage per cell	V_{OUT}		See Table 2		V	
5	STAT Output Low Voltage Output High Voltage	V_{OL} V_{OH}	4.5		0.5	V V	With external 47K pull-down resistor
6	Output Ripple and Noise (at the battery terminal)	V_{RN}		300		mVp-p	Ag112-3, Profile No. 4
7	DC-DC Converter Efficiency	EFF_{DC}		85		%	Ag112-3, Profile No. 5, Vin = 14V
8	Charger Efficiency	EFF_{BAT}		83		%	Ag112-3, Profile No. 5, Vin = 14V
9	Short-Circuit Duration	T_{SC}			∞	sec	

*Typical figures are at 25°C with a nominal input voltage = 12V and are for design aid only. Not Guaranteed

‡Measured between the GND and the BAT+ pins

10 Package

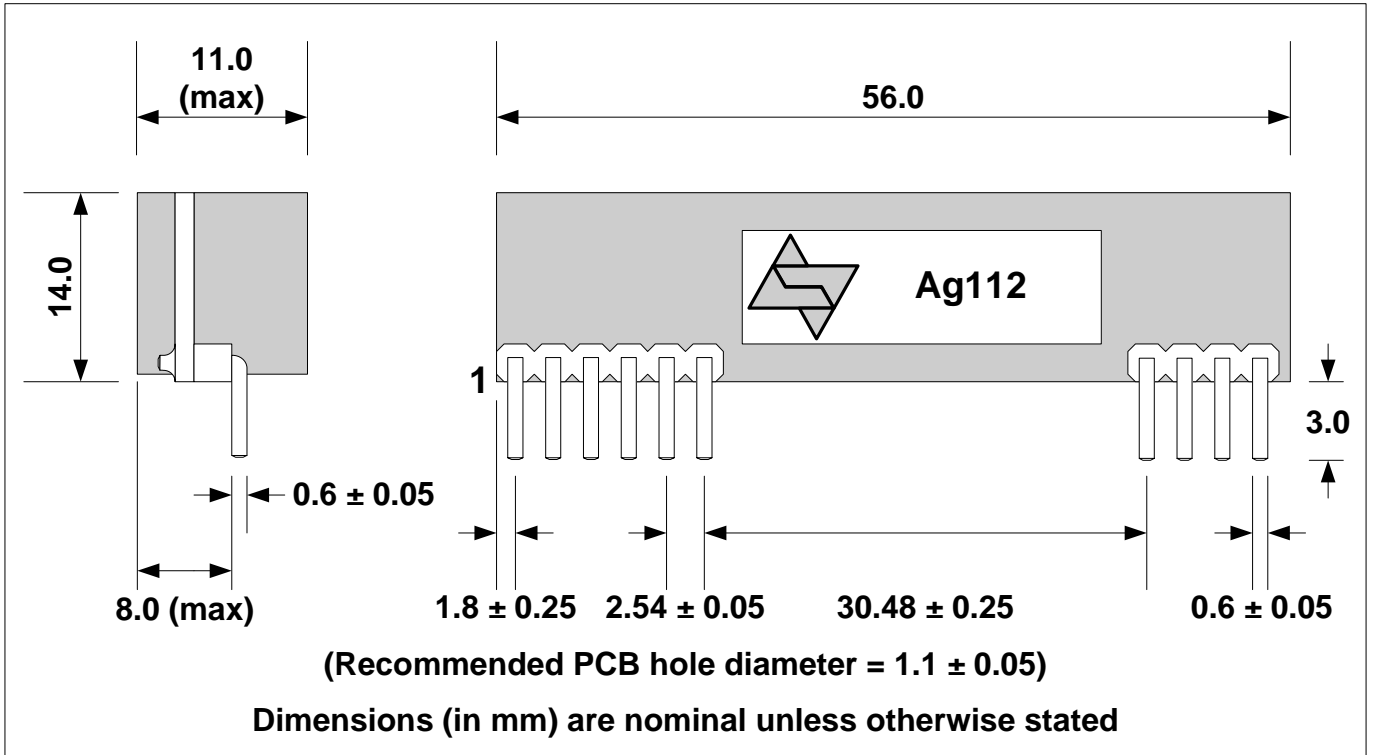

Information published in this datasheet is believed to be correct and accurate. Silver Telecom assumes no liability for errors which may occur or for liability otherwise arising out of use of this information or infringement of patents which may occur as a result of such use. No license is granted by this document under patents owned by Silver Telecom or licensed from third parties by Silver Telecom. The products, their specification and information appearing in this document are subject to change by Silver Telecom without notice.