

Silvertel

**EVAL Kit 200W
User Manual**

Rev 1.0 – June2011

1 Table of Contents

1	Table of Contents	1
2	Table of Figures	1
3	Kit Contents	2
4	Introduction	2
4.1	<i>EvalAg6700</i>	2
4.2	<i>EvalAg5700</i>	2
5	Evaluation Board Description for Ag6700	3
5.1	<i>Input Selection</i>	3
5.2	<i>Input Switch</i>	3
5.3	<i>Ag6700 Information</i>	4
6	Evaluation Board Description for Ag5700	4
6.1	<i>Input Selection</i>	4
6.2	<i>Input operation</i>	4
6.3	<i>Output Adjustment</i>	5
6.4	<i>Diode Selection</i>	5
6.5	<i>Heat Sink</i>	5
6.6	<i>Ag5700 Information</i>	6
7	Set-up	6
7.1	<i>Power Supply Input</i>	6
7.2	<i>Data Input</i>	7

2 Table of Figures

Figure 1:	Board Layout.....	3
Figure 2:	Board Layout.....	4
Figure 3:	Output Adjustment	5
Figure 4:	Basic set-up	6
Figure 5:	Laptop Setup.....	7

3 Kit Contents

- Ag5700 Evaluation Board
- Ag5700 PD Module
- Ag6700 Evaluation Board
- Ag6700 PSE Module
- Heat sink attached to Ag5700 Evaluation Board

4 Introduction

This manual is intended to be a guide to using the “EVALAg5700 evaluation board” along with the “EVALAg6700 evaluation board” with the following Silver Telecom Power Over Ethernet (POE) modules.

4.1 EvalAg6700

The EVALAG6700 evaluation board can be powered from a 58V power supply suitable of delivering up to 60V at 5A.

The data is supplied to the EVALAG6700 through connector J2 and is passed through the data transformer and through to J3. The output power from the PSE is sent to the Ag5700 via J3 (see [Figure 1](#)). When the Ag6700 input is on, LED1 will be illuminated. When the PSE module output is on, LED2 will be illuminated.

The EVALAG6700 evaluation board will work with the following PSE module: -

Ag6700

4.2 EvalAg5700

The EVALAG5700 evaluation board can be powered from the EVALAg6700 evaluation board that provides 58Vdc and up to 4A to the EVALAg5700 board through connector J1.

The data and power input to the EVALAG5700 is supplied from the EVALAG6700 to the EVALAG5700 via connector J1 (see [Figure 2](#)). Data is passed through the data transformer and through to the data output of connector J2.

The output power from the Ag5700 is supplied to the connectors JP1, JP2 and JP3 (see [Figure2](#)), where JP2 provides the positive +24Vdc and JP3 provides the ground path of 0Vdc.

When there is power connected to the EVALAg5700 board then LED1 will be illuminated. LED2 will be illuminated when the PD module outputs +24Vdc.

The EVALAG5700 evaluation board will work with the following PD module: -

Ag5700

5 Evaluation Board Description for Ag6700

5.1 Input Selection

The EVALAG6700 evaluation board should be powered using a DC Power supply delivering +58V to either JP1 or pin 1 of J1 and 0V to either JP2 or pin 2 of J1. If LED1 is illuminated then there is power going to the Ag6700 input.

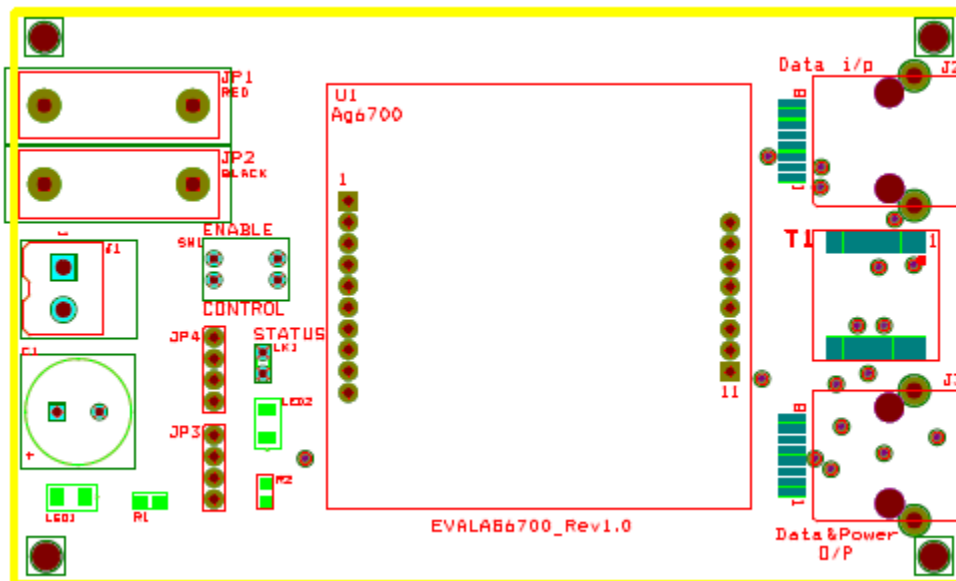

Figure 1: Board Layout

5.2 Input Switch

Applying the power to the Ag6700 is achieved by switching SW1-1 (ENABLE) into the ON position. The output power is limited to 20W when the CONTROL switch SW1-2 is OFF. To obtain full power from the Ag6700 (200W), the CONTROL switch must be set to ON.

LK1 is connected to the Status pin of the Ag6700, if a link is present LED2 will light to show the current output state of the Ag6700. The output of the Ag6700 is in full operation when LED2 is lit, conveying there is output power. When the LED flashes this symbolizes that a fault has occurred e.g. a short circuit.

5.3 Ag6700 Information

Full operating conditions and feature set for the Ag6700 can be found in the Ag6700 datasheet, available from www.silvertel.com

6 Evaluation Board Description for Ag5700

6.1 Input Selection

The EVALAg5700 evaluation board should be powered using the EVALAg6700 evaluation board delivering power and data. If LED1 is illuminated then there is power going to the Ag5700 input.

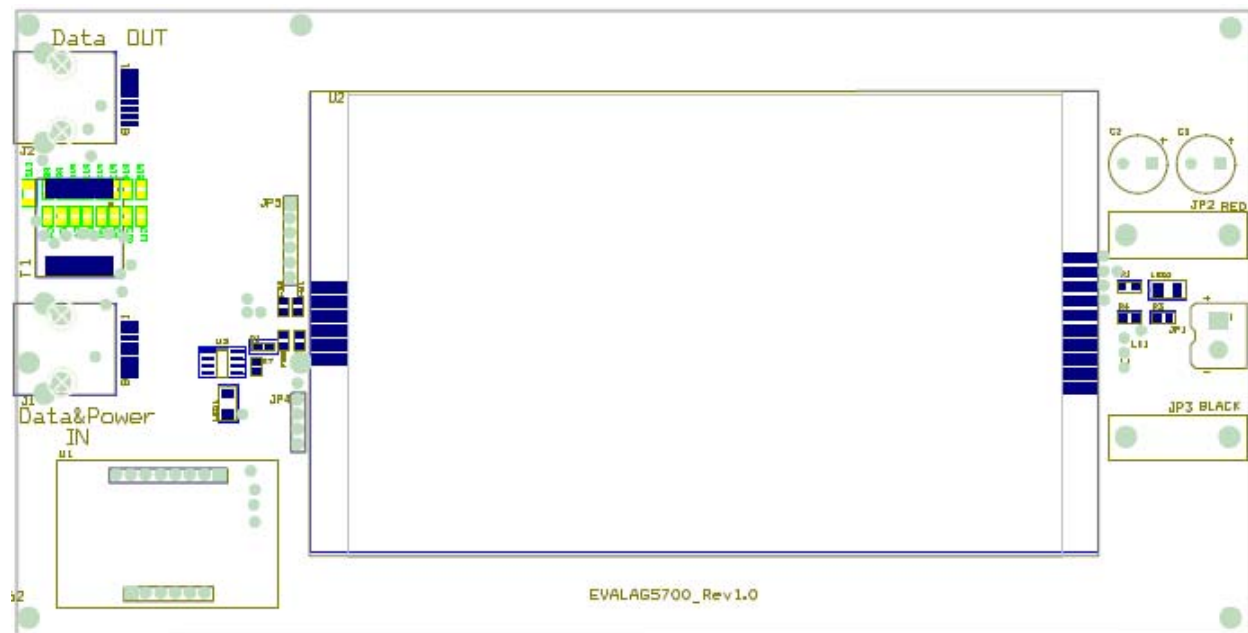

Figure 2: Board Layout

6.2 Input operation

Data and Power is supplied to the EVALAg5700 evaluation board through connector J1 which is sent to the data transformer T1 where the power and data are separated from each other.

The data is routed to J2 and the power output goes through the selected diode bridge U1 (see [Diode Selection](#)). Applying the power to the Ag5700 is achieved through the output of the diode bridge via ferrite beads, (which prevent high frequency noise going back up the cable and reduces EMI). The Ag5700 distributes the output power of up to 200W through the 4mm plugs, JP2/JP3 or the screw terminal JP1.

6.3 Output Adjustment

The Ag5700 has an ADJ pin, which allows the output voltage to be increased or decreased from its nominal value. Figure 3: Output Adjustment shows how the ADJ pin is connected.

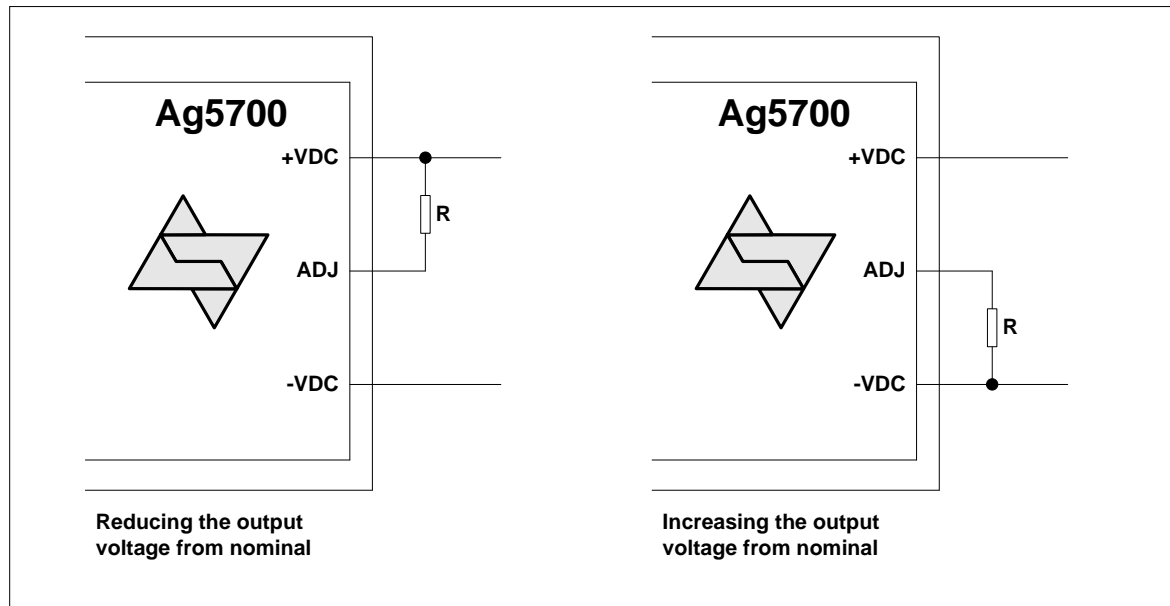

Figure 3: Output Adjustment

LK1 is connected to the ADJ pin for the PD module to either increase or decrease the voltage. When the link is connected to the top and middle pins, the Ag5700 output voltage will be increased to its output of 27V. When the link is connected to the bottom and middle pins of LK1 then the Ag5700 output voltage will be decreased to its minimum of 19.5V.

6.4 Diode Selection

Due to the differences in the voltage drop across the various diodes, U1 is pluggable so that a Schottky diode or MOSFET bridge maybe chosen.

6.5 Heat Sink

As the Ag5700 is a 200W power supply thermal management is essential, as such it is designed to be used with a heat sink at all times to distribute the heat away from the board so the board can run at full operation.

The heat sink attached is 2mm aluminum which covers the whole Eval board. For full details on the thermal management see section 8 of the Ag5700 datasheet under Operating Temperature Range.

6.6 Ag5700 Information

Full operating conditions and feature set for the Ag5700 can be found in the Ag5700 datasheet, available from www.silvertel.com

7 Set-up

7.1 Power Supply Input

Figure 4 shows the basic set up using the EVALAG5700 evaluation board along with the EVALAG6700 evaluation board with a power supply input to JP1.

The equipment required: -

- Power supply Input +58V IN e.g. Meanwell SP-240-48 available form mouser which will give 56V
- Ethernet Data Cable (CAT5e cable) Input and Output
- CAT5e or CAT6 interlink cable(between EvalAg6700 and EvalAg5700)
- Output power cable

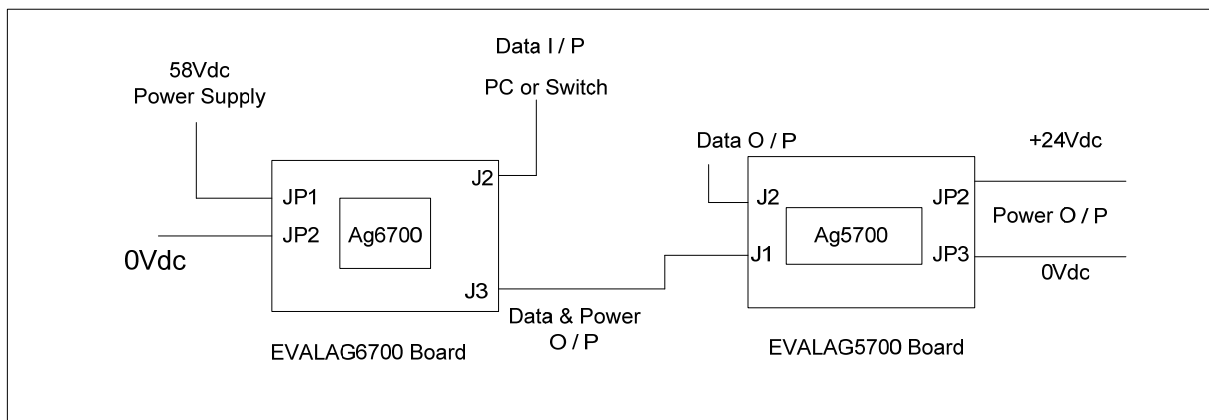

Figure 4: Basic set-up

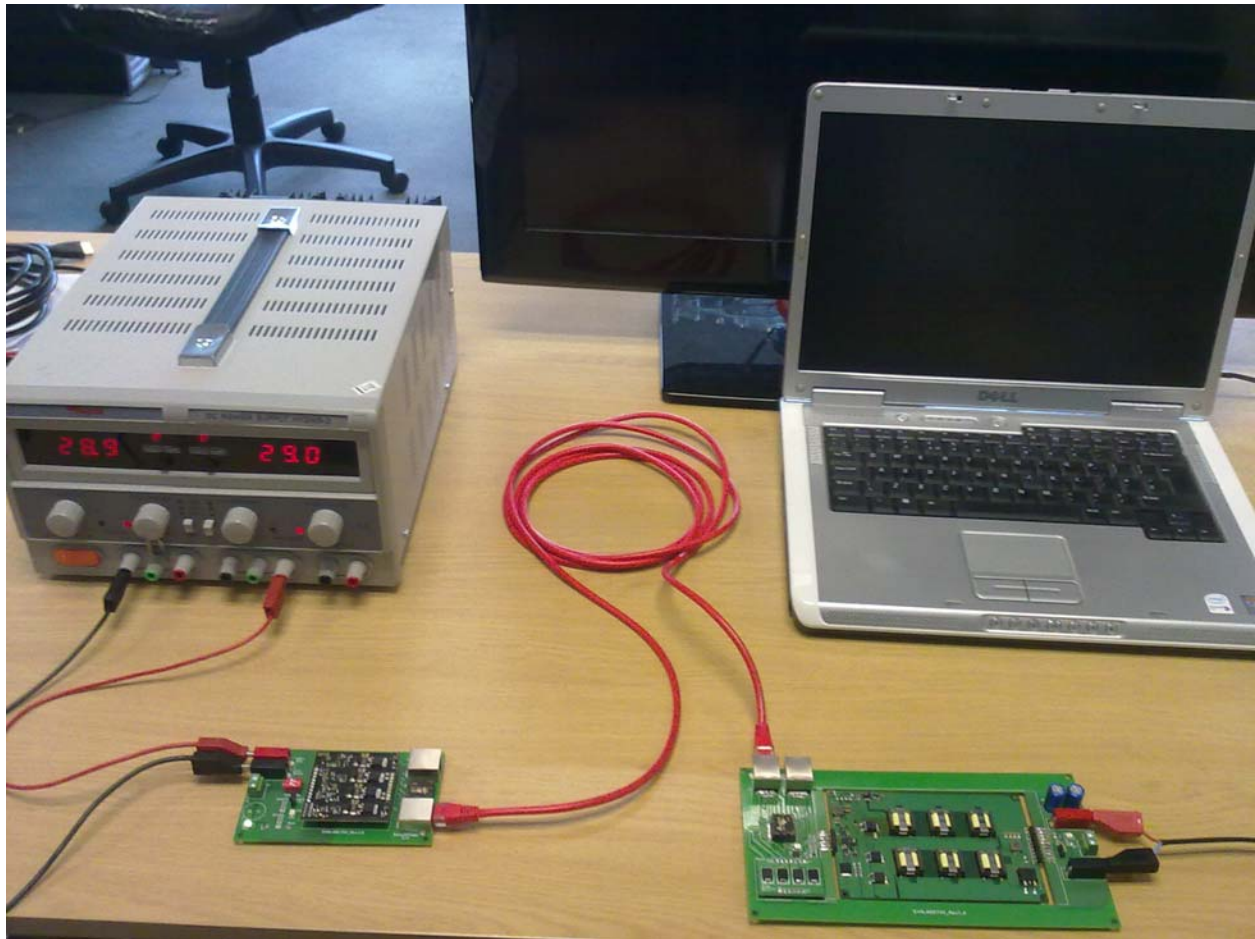

Figure 5: Laptop Setup

7.2 Data Input

To pass data via the Evaluation boards, the data input e.g. Internet, can be connected to J2 on the Ag6700 Eval Board using a cat5e cable. The data is then passed through the data transformer, where power is added and sent out via connector J3 of the Ag6700 Eval Board. The Data and power is extracted through J1 of the EVALAg5700 board and then divided into its separate power and data through the data transformer. The data output is then available from J2 of the EvalAg5700 Board, which can then be connected to your device.