



**POE Evaluation Board
User Manual**

Rev 1.3 – June 2011

1 Table of Contents

1	Table of Contents	1
2	Table of Figures	1
3	Introduction	2
4	Board Description	2
4.1	<i>Input Selection</i>	2
4.2	<i>Class Programming</i>	3
4.3	<i>Output adjustment</i>	4
4.4	<i>Output filter</i>	4
4.5	<i>Output indication</i>	4
5	Equipment Required	5
6	Using the Board	6
6.1	<i>Typical Application</i>	6

2 Table of Figures

Figure 1:	Board Layout.....	3
Figure 2:	Basic set-up	5
Figure 3:	Example set-up	6

3 Introduction

This manual is intended to be a guide to using the “POE evaluation board” with Silver Telecom Powered Device (PD) modules.

The POE evaluation board can be powered using the spare pair in the CAT5e cable (pins 4 & 5 and pins 7 & 8) by Midspan equipment. In addition to this the POE evaluation board has on-board magnetics. This can extract the power from the center tap of the data pair (pins 1 & 2 and pins 3 & 6) used by Endspan equipment.

4 Board Description

The POE evaluation board will work with the following products: -

Ag8003	-	Ag8005	-	Ag8012	-
Ag8103	-	Ag8105	-	Ag8112	-
Ag8205	-	Ag8205	-	Ag8212	-
Ag9033	-	Ag9050	-	Ag9120	-
Ag9203	-	Ag9205	-		-
Ag9403	-	Ag9405	-	Ag9412	-
Ag9603	-	Ag9605	-	Ag9612	-
					Ag9424

The input data and power is supplied to the board through connector J1. The data is passed through to the peripheral equipment via J2, with the power from the PD module is supplied via either J3 & J4 or J5 (see Figure 1).

4.1 Input Selection

The POE evaluation board has on-board bridge rectifiers that can be used or bypassed using links LK1 to LK4 (see Figure 1) depending of which PD module is being used.

For modules that already have internal bridge rectifiers, the POE evaluation board rectifiers can be bypassed by setting links LK1 to LK4 to position A.

For modules that do not have internal bridge rectifiers, the POE evaluation board rectifiers can be used by setting links LK1 to LK4 to position B.

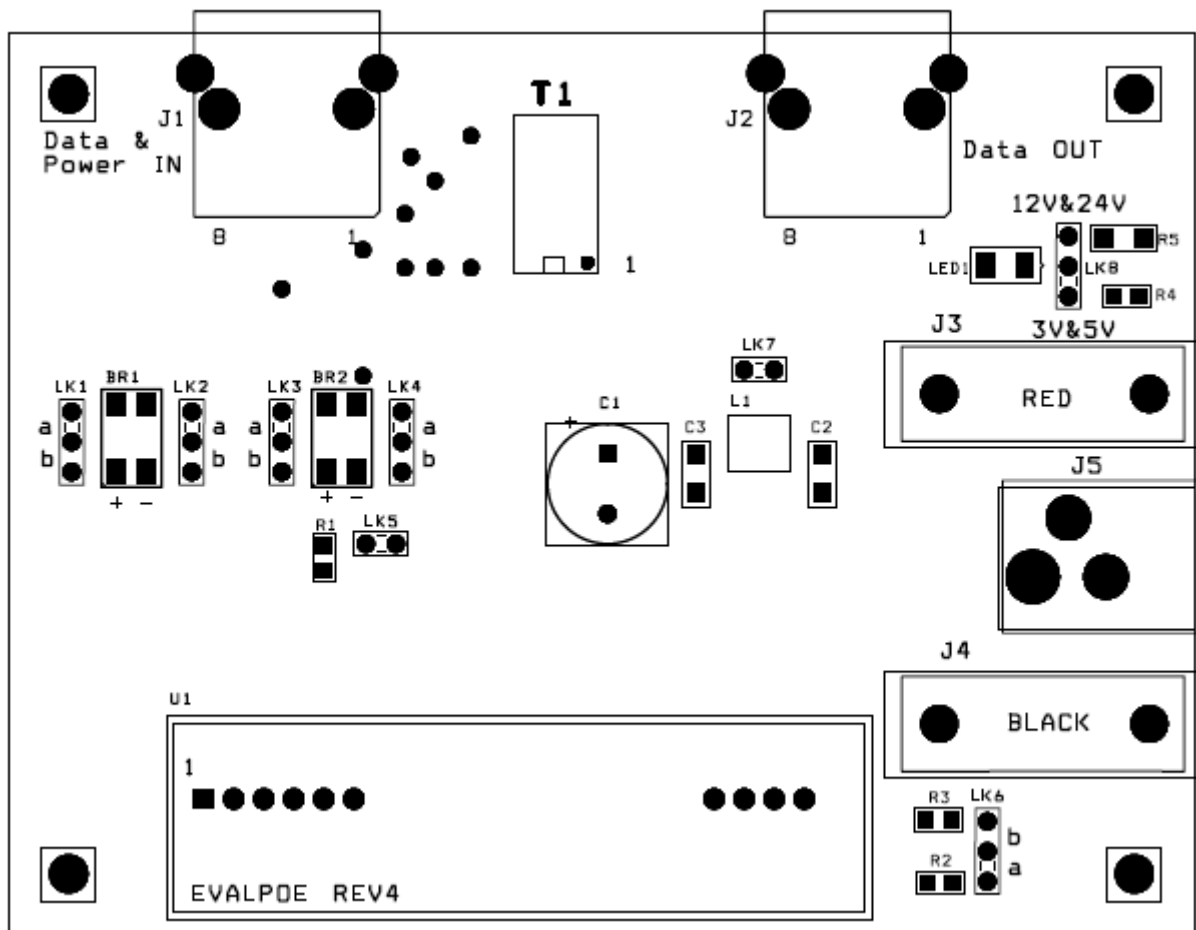

Figure 1: Board Layout

4.2 Class Programming

Resistors R1 can be used to set the (optional) power classification of the module.

The evaluation board has a 249R fitted, which will set the PD module as class 3 when LK5 is fitted (see Figure 1). This can be change if required, see the table in the power classification section in the datasheets for resistance values.

If LK5 is not fitted the PD module will default to Class 0 (0.44W to 12.95W).

4.3 Output adjustment

The output voltage of the PD module can be adjusted by connecting the ADJ pin to either GND or +VDC. LK6 can be used to adjust the output voltage (see Figure 1).

On the POE evaluation board R2 and R3 are supplied with a 0 Ohm link to give maximum adjustment, see the output adjustment section in the datasheet for more information.

Ag8000, Ag8100 and Ag8200 series

With LK6 fitted in position A the left pin the output voltage will increase.

With LK6 fitted in position B the right pin the output voltage will decrease.

Ag9000, Ag9200, Ag9400 and Ag9600

With LK6 fitted in position B the left pin the output voltage will increase.

With LK6 fitted in position A the right pin the output voltage will decrease.

4.4 Output filter

There is a filter L1, C2 and C3 connected to the output of the module, this can be bypassed by fitting link LK7.

This filter is primarily used with the Ag9600 series.

4.5 Output indication

When the module output is ON - LED1 will be illuminated.

LK8 can be set to "3V & 5V" or "12V & 24V" to match the output voltage of the module.

5 Equipment Required

Figure 2 shows the basic set up using the POE evaluation board with a Midspan.

The equipment required: -

- Midspan or Endspan PSE (Power Sourcing Equipment)
- Peripheral (or Test) Equipment
- CAT5e cables
- Output power cable
- Mains cable

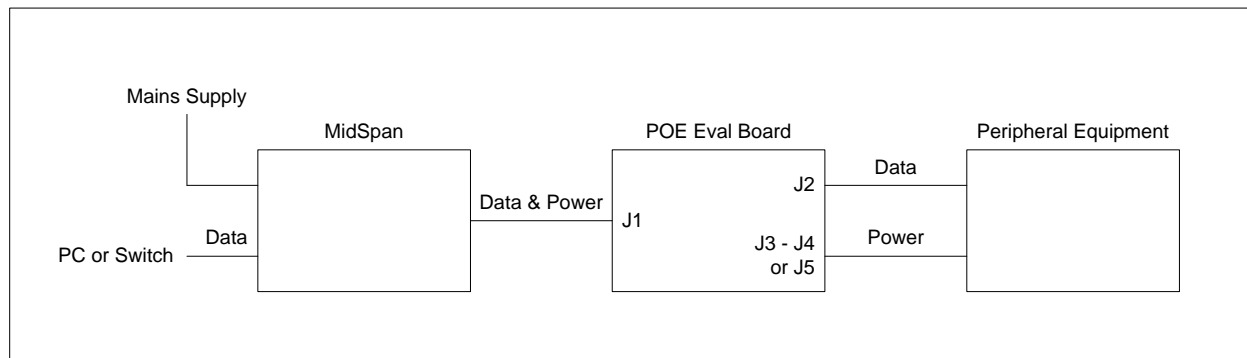

Figure 2: Basic set-up

The POE evaluation board can be powered from a Midspan PSE, an Endspan PSE, or from a 48V power supply with a current limit =>400mA.

6 Using the Board

6.1 Typical Application

Figure 3 shows an example set-up using an Ag9405 powered by a Midspan and supplying +5V to a DLink DCS-900 ethernet camera.

The PC ethernet port is connected to the data input of the Midspan via a short Cat5e patch cable. The Data & Power output from the Midspan is connected to the input of the POE evaluation board (J1) via a CAT5e crossover cable. The data output of the POE evaluation board is connected to the data port of the ethernet camera via a short CAT5e patch cable. The (+5V) power output from the POE evaluation board (J5) connects to the dc input of the ethernet camera.

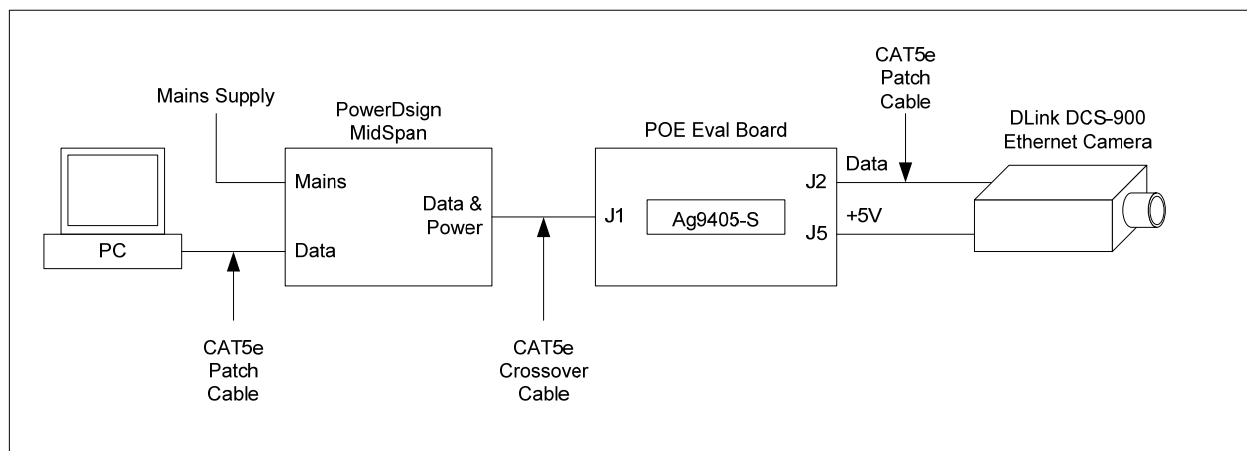

Figure 3: Example set-up